



SCANDIA COMBI MANUAL

SCAC-60NSF(UK)

SCAC-80NSF(UK)

SCAC-90NSF(UK)

*Congratulations on your purchase of a SAWO heater/steam generator.
Please read the manual carefully before using the product.*

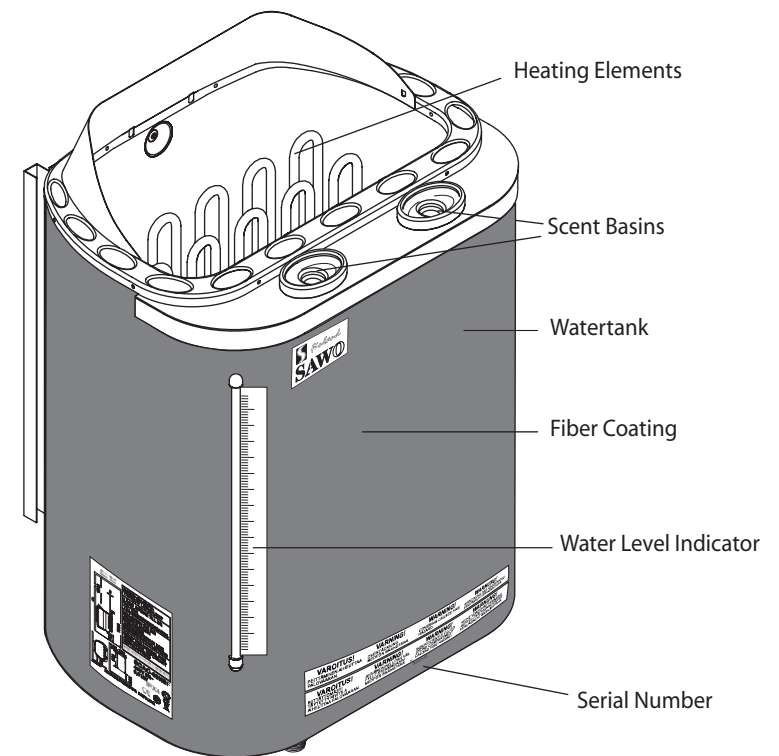

www.sawo.com
sawo@sawo.com

Subject to change without notice.

**ELECTRIC
SAUNA
HEATER /
STEAM
GENERATOR**

ENGLISH

1. Instructions for use

1.1. Sauna Stones

Never use the heater without stones as it may cause a fire. Only the original Sawo Rocks are recommended. Do not use ordinary stones. They do not possess good heating capacity, easily break and may emit harmful substances.

Wash the stones before placing them into the sauna heater to remove any traces of dust. Stones of unspecified sizes should not be used. Place the larger stones at the bottom of the stone compartment and the smaller ones on top. Do not arrange them tightly so that air can move freely. Too tightly placed stones shorten life span of the heating elements remarkably. The stones should be fitted loosely, and not wedged between the heating elements. Very small stones should not be put into the combi heater at all. The stones should evenly cover the heating elements. Refer to Fig.1.

The stones should completely cover the heating elements. However, they should not form a high pile on the elements. The stones disintegrate with use. Therefore, they should be rearranged at least once a year or even more often if the sauna is in frequent use (maximum 500 hours). At the same time, any pieces of stones should be removed from the bottom of the heater, and disintegrated stones should be replaced with new ones.

No such objects or devices should be placed inside the combi heater stone space or near the heater that could change the amount or direction of the air flowing through the heater, thus causing the resistance temperature to rise too high, which may set the wall surfaces on fire!

IMPORTANT:

Do not use porous stones, ceramic "stones" or any ordinary type of stones. It might cause defects of the heating elements and may emit harmful substances.

Defects caused by wrongly arranged stones and usage of stones not recommended by SAWO will automatically void the warranty.

NO CERAMIC STONES

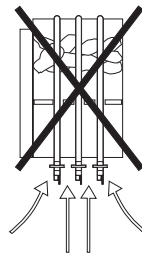
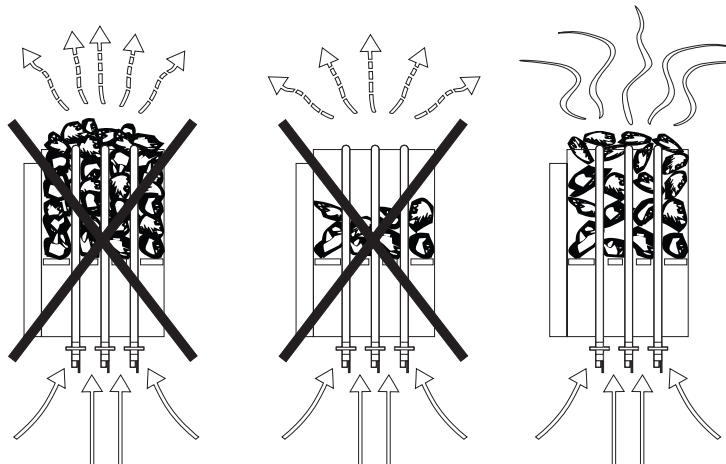

Fig. 1

Piling of the sauna stones



1.2. Heating of the Sauna, sauna heater operations only

Before you switch the combi heater on always check that there aren't any things over the combi heater or in near distance of the heater. (See clause 1.6. Warnings).

When the combi heater is switched on for the first time, both the combi heater and the stones emit smell. To remove the smell, the sauna room needs to be efficiently ventilated.

The purpose of the combi heater is to raise the temperature of the sauna room and the sauna stones to the required bathing temperature. If the combi heater output is suitable for the sauna room, it will take about one hour for a properly insulated sauna to reach that temperature. See item 2.1., (Insulation and Wall Materials of the Sauna Room). A suitable temperature for the sauna room is about +65 to +80°C (9-176°F) (without steam generator operation).

The sauna stones normally reach the required bathing temperature at the same time as the sauna room. If the combi heater capacity is too big, the air in the sauna will heat very quickly, whereas the temperature of the stones may remain insufficient; consequently, the water thrown on the stones will run through. On the other hand, if the combi heater capacity is too low for the sauna room, the room will heat slowly and, by throwing water on the stones, the bather may try to raise the temperature of the sauna. However, the water will only cool down the stones quickly, and after a while the sauna will not be warm enough and the combi heater will not be able to provide enough heat.

In order to make bathing enjoyable, the combi heater capacity should be carefully chosen to suit the size of the sauna room. (See clause 2.3. Combi Heater Output).

1.2.1. Throwing Water on Heated Stones

The air in the sauna room becomes dry when warmed up. Therefore, it is necessary to throw water on the heated stones to reach a suitable level of humidity in the sauna.

The humidity of the air in the sauna room is controlled by the amount of water thrown on the stones. A correct level of humidity makes the bather's skin sweat and makes breathing easy. By throwing water on the stones with a small ladle, the bather should feel the effect of air humidity on his skin.

Staying in the hot sauna for long periods of time makes the body temperature rise, which may be dangerous.

If an excessive amount of water is poured on the stones, only part of it will evaporate and the rest may splash as boiling hot water on the bathers.

Never throw water on the stones when there are people near the combi heater, because hot steam may burn their skin.

1.2.2. Sauna Water

The water to be thrown on the heated stones should meet the requirements of clean household water.

Calcareous water leaves a white, sticky layer on the stones and metal surfaces of the combi heater. Calcification of the stones deteriorates the heating properties.

Ferrous water leaves a rusty layer on the surface of the combi heater and elements, and causes corrosion. The use of humous, chlorinated water and seawater is forbidden.

Only special scents designed for sauna water may be used. Follow the instructions given on the package.

1.3. Steam Generator

The combi heater includes a steam generator to produce steam inside the sauna room. The steam generator has a 5 litres tank which produces steam for about 1 hour 30 minutes (with 5 litres of water) with setting MAX on the external control unit.

To ensure ideal humidity, the sauna temperature should be between 40 and 50°C (140 and 122°F), and the steam generator should be left on for about 30 minutes to pre-heat the sauna and produce sufficient amount of steam.

1.3.1. Filling the water reservoir

Water can be poured through the openings of the scent basins or by removing the reservoir cover first (refer to section 6). Water should be poured carefully to avoid spillage on electric parts of the steam generator. The maximum capacity of the tank is approximately 5 litres. If water in the tank exceeds MAX on the level indicator, water from the indicator tube end will spill on the floor. The water level can conveniently be monitored through the water level tube.

If a FILL message appears on the external control unit cold water shall be poured through the openings of the scent basins by carefully removing the scent basins, which might be hot. Do not attempt to remove the cover as it is extremely hot.

Before turning on the steam generator, make sure that sufficient amount of water is in the reservoir.

1.3.2. Low water level indication

The combi heater has a low water detection system which reminds you on refilling water before the steam generator tank runs dry. To avoid the activation of the low water detection system, refill water once the water level reaches the REFILL mark on the water level indicator tube (about 1.5 litre water left in the tank). Should you miss to refill water at that point, the low water detection system will automatically turn off the steam generator heater at about 1 litre and display a FILL message together with a buzzer tone on the external control unit. Observe caution when refilling water as the steam generator tank is still hot (refer to section 1.3.1). After refilling water, the steam generator heater turns on again after a short while.

If no water is refilled upon the FILL message appears on the display of the control unit, the steam generator will turn on again after a few minutes. The FILL message is repeatedly displayed until water is filled in the tank or the unit is turned off. In order to preserve the heating plate and life span of your combi heater avoid "dry boiling" of the steam generator.

1.3.3. Draining the water reservoir

In order to ensure best water quality the water reservoir must always be emptied after use. This procedure removes impurities condensed in the reservoir as result of evaporation. Since the water in the reservoir is very hot immediately after use, it should be drained only after the water has cooled down for a few hours after turning the steam generator off. To drain the tank turn the ball valve handle at the bottom of the steam generator tank counterclockwise until water flows. Provide a container (i.e. a bowl) to collect the water. After the tank is completely drained clean the tank with a household brush and water to remove impurities accumulated inside the tank then flush the tank with water and close the ball valve by turning its handle clockwise. Do not forget to refill water before turning the steam generator on again. Do not let the steam generator tank run dry as an alternative method of draining the water. The lifespan of your combi heater will be shortened.

1.3.4. Cleaning the water reservoir

Impurities from water, e.g. lime, will accumulate on the walls of the steam generator's water reservoir. For decalcification we recommend decalcifying agents intended for household appliances, e.g. coffeemakers and water kettles. These agents are to be used as instructed by the manufacturer. The outside of the steam generator can be cleaned with a damp cloth. When cleaning the outside, ensure that the steam generator's power switch is in off position. Before cleaning inside the water tank remove the cover first (refer to section 6). For cleaning use a household brush. Do not use a steel brush as this might damage the tank wall or bottomplate. Do not attempt to clean the tank by hand to avoid injuries caused by tank edges. We recommend to clean the inside of the tank (including side compartment) after every second use.

1.3.5. Using scents

Liquid scents can be used with the combi heater to make your sauna bath more enjoyable. Scents can be poured in the provided scent basins inserted in the water reservoir cover (refer to section 7). Avoid pouring scents while the steam generator is on. The hot steam might cause burns. The scent basins shall be rinsed with water after using them with scents.

1.4. Drying the sauna

The sauna room must always be allowed to dry thoroughly after the steam generator has been used. In order to speed up the drying process, sauna heater and ventilation can be used at maximum setting. If the combi heater is supporting the drying process of the sauna room, remember to turn off the combi heater after the drying is completed.

1.5. How to Use the Sauna

- Leave your clothes in the dressing room. You should also have a clean set of clothes to wear after the sauna.
- Take a shower before you enter the sauna.
- Enter the sauna and sit on the bench. You may want to use a small towel to sit on.
- In Sauna Heater operation mode you may increase humidity of the sauna room by throwing water on the stones of the heater. The recommended temperature in the sauna is 70 to 90°C (158-194°F), at most 100°C (212°F). In Steam Generator mode, the recommended temperature in the sauna room is 40 to 50°C (104 to 122°F).
- Leave the sauna room when you feel hot enough. Cool off by taking a shower or a swim or just by sitting in room temperature or outside. Have a drink if you feel thirsty, but avoid alcohol in the sauna.
- You may go back to the warm sauna room, taking your time to relax and enjoy the sauna atmosphere. You can repeat the hot-cold cycle as many times as you feel comfortable. Two rounds usually suitable for other people.
- After sauna, wash yourself in a shower (or go for a swim).
- Dry yourself with a towel or just by sitting in room temperature.
- Before putting on clean clothes allow enough time for cooling off, otherwise the sweating may still continue.
- Finally, have a peaceful rest and a refreshing drink.

Temperature and Humidity of the Sauna Room

Both thermometers and hygrometers suitable for use in a sauna are available. As the effect of steam on people varies, it is impossible to give an exact, universally applicable bathing temperature or percentage of moisture. The bather's own comfort is the best guide.

The sauna room should be equipped with proper ventilation to guarantee that the air is rich in oxygen and easy to breathe. See item 2.4., (Ventilation of the Sauna Room).

Bathing in a sauna is considered a refreshing experience and good for the health. Bathing cleans and warms your body, relaxes the muscles, soothes and alleviates oppression. As a quiet place, the sauna offers the opportunity to meditate.

1.6. Warnings

- Sea air and a humid climate may corrode the metal surfaces of the combi heater.
- Wiring and repairs must be done by a qualified electrician.
- Do not use the combi heater as a grill, or for boiling food or liquids other than water in the steam generator tank.
- Do not cover the sauna heater. It may cause fire.
- Do not put wood of any kind on the electric heater.
- Do not use the heater as clothes dryer. It may cause fire.
- Never sit on the heater. It is really hot. It can cause serious burns.
- Never use the heater without stones. It may cause fire.
- Do not use chlorinated water (e.g. from the swimming pool or jacuzzi) or seawater.
- Don't put too much water on the heater. "Throw water onto the stones, one to three ladles are enough at a time. After a couple of minutes you can throw little water again."
- Do not fill the steam generator tank up to the top, as boiling water causes an overflow
- Do not turn on the steam generator without water in the tank. Always provide a bowl or similar container to capture drainage water from the steam generator tank.
- Always close the drainage valve after draining the water.

2. The sauna room

2.1. Insulation and Wall Materials of the Sauna Room

In an electrically heated sauna, all the massive wall surfaces which store plenty of heat (such as bricks, glass blocks, plaster etc.), must be sufficiently insulated in order to keep the heater output at a reasonably low level.

A wall and ceiling construction can be considered to have efficient thermal insulation if:

- the thickness of carefully fitted insulating wool inside the house is 100 mm (minimum 50 mm).
- the moisture protection consists of e.g. aluminium paper with tightly taped edges. The paper must be fitted so that the glossy side is towards the inside of the sauna.
- there is a 10 mm vent gap between the moisture protection and panel boards (recommendation).
- the inside is covered by 12–16 mm thick panelling.
- there is a vent gap of a few millimetres at the top of the wall covering at the edge of the ceiling panelling.

When aiming at a reasonable heater output, it may be advisable to lower the ceiling of the sauna (normally 2.1–2.3 m, minimum height 1.9 m). As a result, the volume of the sauna is decreased, and a smaller combi heater output may be sufficient. The ceiling can be lowered so that the ceiling joists are fixed at a suitable height. The spaces between the joists are insulated (minimum insulation 100 mm) and surfaced as described above. Because heat goes upwards, a maximum distance of 1.1–1.2 m is recommended between the bench and ceiling.

NOTE: Consult building safety authorities to find out which part of the fireproof wall may be insulated.

NOTE: The protection of the walls or ceiling with heat protection, such as mineral board fitted directly on the wall or ceiling, may cause the temperature of the wall and ceiling materials to rise dangerously high.

2.1.1.

Blackening of the sauna walls

Wooden material in a sauna, such as panels, blackens with age. The blackening process is sped up by sunlight and the heat from the stove. If the wall surfaces have been processed with protective panel agents, the blackening of the surface of the wall above the stove can be seen quite quickly depending on the protective agent used. The blackening is due to the fact that the protective agents have less resistance to heat than unprocessed wood do.

This

has been proven in practical tests. The micronic mineral aggregate that crumbles from the stones on the stove may blacken the wall surface near the stove.

When following the manufacturer's approved guidelines in the installation of the sauna heater, the heater will not heat up enough to endanger the flammable material in the sauna room. The maximum temperature allowed in the wall and ceiling surfaces of the sauna room is 140°C (284°F).

Sauna heaters equipped with proper approval marks meet applicable regulations for sauna installations. Third Party authorities monitor that the regulations are being followed.

2.2. Sauna Room Floor

Due to a large variation in temperature, the sauna stones disintegrate in use. Small pieces of stone are washed down on the sauna room floor along with the water thrown on the stones. Hot pieces of stone may damage plastic floor coverings installed underneath and near the heater.

A light-coloured joint grout, used for a tiled floor, may absorb impurities from the stones and water (e.g. iron content).

To prevent aesthetic damage (due to the reasons presented above) only dark joint grouts and floor coverings made of rock materials should be used underneath and near the combi heater. Make sure that the water dripping onto the sauna floor enters the floor drain

2.3. Combi Heater Output

When the walls and ceiling are covered with panels, and the insulation behind the panels is sufficient to prevent thermal flow into the wall materials, the combi heater output is defined according to the cubic volume of the sauna.

If the sauna has visible uninsulated wall surfaces, such as walls covered with brick, glass block, concrete or tile, each square metre of said wall surface causes the cubic volume of the sauna to increase by 1.2 m³. The combi heater output is then selected according to the values given in the table.

Because log walls are heated slowly, the volume of a log sauna should be multiplied by 1.5, and the combi heater output should then be selected on the basis of this information.

2.4. Ventilation of the Sauna Room

Sufficient ventilation is extremely important for the sauna. The air in the sauna room should be changed six times per hour. The fresh air pipe should come directly from outside. According to the newest research results, the pipe should be located at a minimum height of 50 cm above the heater. The pipe diameter should be about 50–100 mm.

Exhaust air should be led from the lower part of the sauna directly into the air chimney, or, by using an exhaust pipe starting near the floor level, into a vent in the upper part of the sauna. Exhaust air can also be led out through an exhaust air vent in the washing room through a 50 mm opening under the sauna door. The exhaust air of the sauna room should be taken from as far from the heater as possible, but near the floor level. The crosscut area of the exhaust air vent should be twice that of the supply air pipe.

For the above-mentioned system, mechanical ventilation is necessary.

If the heater is mounted in a ready-made sauna, the instructions of the sauna manufacturer should be followed when arranging ventilation.

The series of pictures in Fig. 2 shows examples of ventilation systems for a sauna room.

2.5. Hygienic Conditions of the Sauna Room

Good hygienic standards of the sauna room will make bathing a pleasant experience. The use of sauna seat towels is recommended to prevent sweat from flowing onto the platforms. The towels should be washed after each use. Separate towels should be provided for guests. It is advisable to vacuum or sweep the floor of the sauna room in connection with cleaning. In addition, the floor may be wiped with a damp cloth. The sauna room should be thoroughly washed at least every six months. Brush the walls, platforms and floor by using a scrubbing-brush and sauna cleanser. Wipe dust and dirt from the combi heater with a damp cloth.

Fig. 2 Ventilation of the sauna room

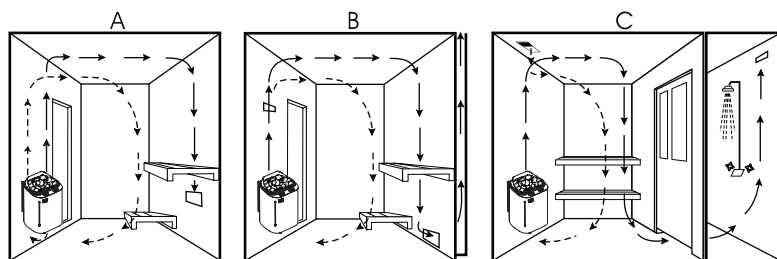

1. Air supply vent.
2. Optional air supply vent, if mechanical exhaust ventilation is used. The opening is located 50 cm above the heater.
3. Exhaust air vent.
4. Possible drying valve, which is closed during heating and bathing, the sauna can also be dried by leaving the door open after bathing.
5. If there is an exhaust vent in the washing room only, there should be a minimum 50 mm opening under the sauna room door. Mechanical ventilation is recommended.

3. Installation

It is recommended that the combi heater is placed on the wall nearest to the door. The air circulation created by the door should work together with the hot air generated by the heater. For safety and convenience, follow the minimum safety distances as provided in Fig. 3. Do not install the combi heater to the floor or wall niche. Install only one heater in a sauna room. The temperature sensor has to be mounted above the heater. Check the manual of the external control unit for further instructions.

Be sure to build a strong foundation for the mounting rack (e.g. cross struts in sauna paneling) or reinforce the wall with a thick board to prevent the heater from collapsing. Attach the heater to the wall with the aid of the mounting rack. Screws are provided for fastening of the rack to the wall. To affix the heater to the rack, lift the heater and fit the nuts that are placed at the back of the heater to the slots on both sides at the top of the rack. Lock at least one of the side screws to prevent the heater from being accidentally moved.

A certified electrician must do the installation of the heater to ensure safety and reliability. Improper electrical connections can cause electric shock or fire. Refer to the electrical diagram in Fig. 4.

The combi heater gets very hot. To avoid the risk of accidental contact with the combi heater, it is recommended that a heater guard is provided. Follow the directions given in Fig. 5.

Fig. 3

Safety distances for the combi heater

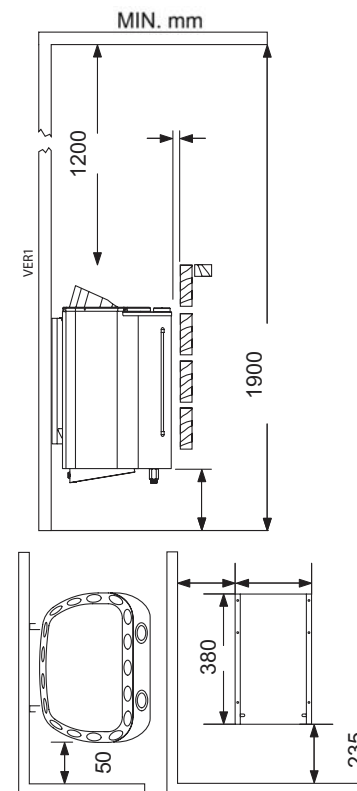

Fig. 5

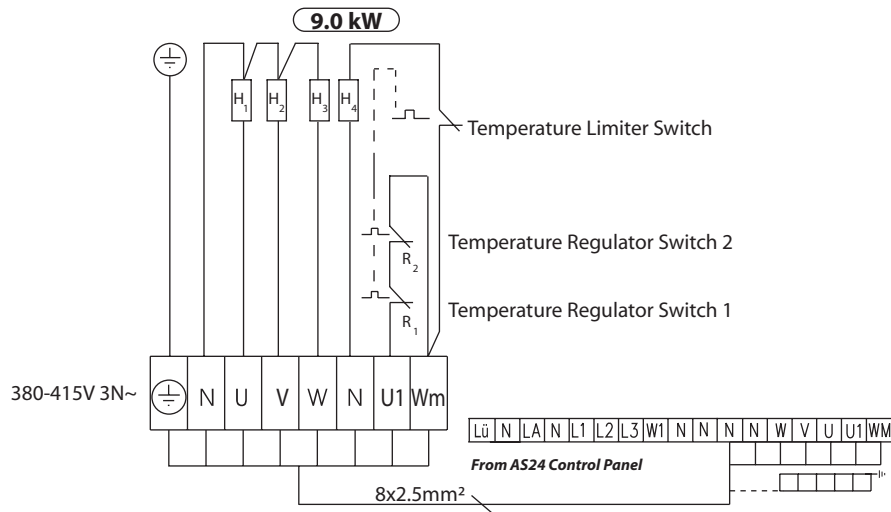
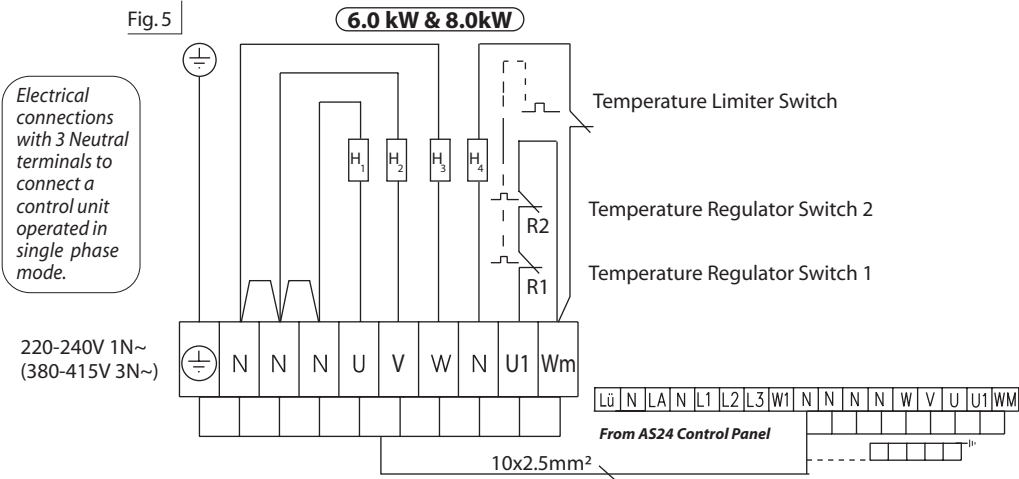
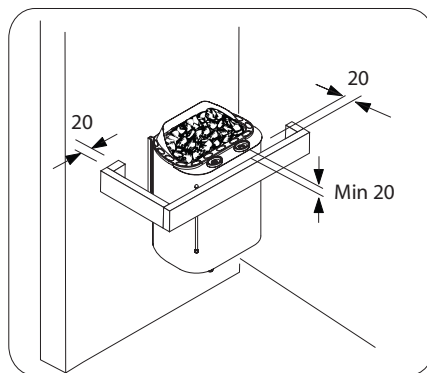

Fig. 6



3.6. Electrical Connections

The combi heater may only be connected to the electrical network in accordance with the current regulations by an authorised, professional electrician.

The connection cable must be of rubber cable type H07RN-F or its equivalent.

NOTE: Due to thermal embrittlement, the use of PVC-insulated wire as the connection cable of the combi heater is forbidden.

3.7. Electric Heater Insulation Resistance

When performing the final inspection of the electrical installations, a "leakage" may be detected when measuring the combi heater's insulation resistance. The reason for this is that the insulating material of the heating resistors has absorbed moisture from the air (storage transport). After operating the heater for a few times, the moisture will be removed from the resistors.

4. Technical data

To determine the correct sauna room size for the heater, refer to the technical data in Fig.6.

HEATER MODEL	kW	HEATING ELEMENT		SAUNA ROOM		SUPPLY VOLTAGE	SIZE OF HEATER			SIZE OF WIRE (mm ²)	STONES	CONTROL
		kW	TYPE NUMBER	MIN (m ²)	MAX (m ²)		WIDTH (mm)	DEPTH (mm)	HEIGHT (mm)			
SCAC-60NSF(UK)	6,0 kW	3 x 2,0 kW 1 x 2,0 kW	SCA200 COM200	5	9	220-240V 1N~ (380-415V 3N~)	421	288	445	10x2.5 mm ²	18-22 kg	separate
SCAC-80NSF(UK)	8,0 kW	3 x 2,66 kW 1 x 2,0 kW	SCA266 COM200	7	13	220-240V 1N~ (380-415V 3N~)	421	288	514	10x2.5 mm ²	18-22 kg	separate
SCAC-90NSF(UK)	9,0 kW	3 x 3,0 kW 1 x 2,0 kW	SCA300 COM200	8	14	380-415V 3N~	421	288	514	8x2.5 mm ²	18-22 kg	separate

Fig. 6 Technical data

5. Troubleshooting

If the steam generator doesn't work, check the following:

- Is the combi heater connected to the power supply?
- Is the steam generator turned on?
- Is sufficient water in the reservoir?
- Is the instruction regarding temperature setting of the sauna heater given in the manual of the external control unit followed?
- Was a FILL message to refill the container displayed on the external control unit? It takes a few minutes before the steam generator heater turns on again.

If heater doesn't work, check the following:

- that the heater has been switched to operating time not to the presetting time.
- source of electricity to the heater has been switched on.
- the heater's fuses in the household's main fuse box.
- the overheat guard has been resetted if the heater has overheated earlier.
- Consult a qualified technician if troubleshooting is not successful.

6. Assembly of Ball Valve

Fig. 7

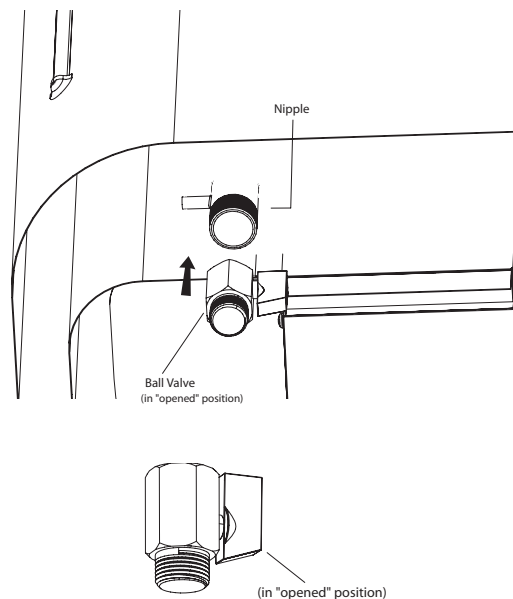

This part is available in the box and shall be attached to the nipple during installation as shown above. Make sure that the nipple's thread has been provided with Teflon tape, and that the handle is in "closed" position after installation.

7. Attaching Scent Basins

Attach the scent basins as shown in Fig. 8.

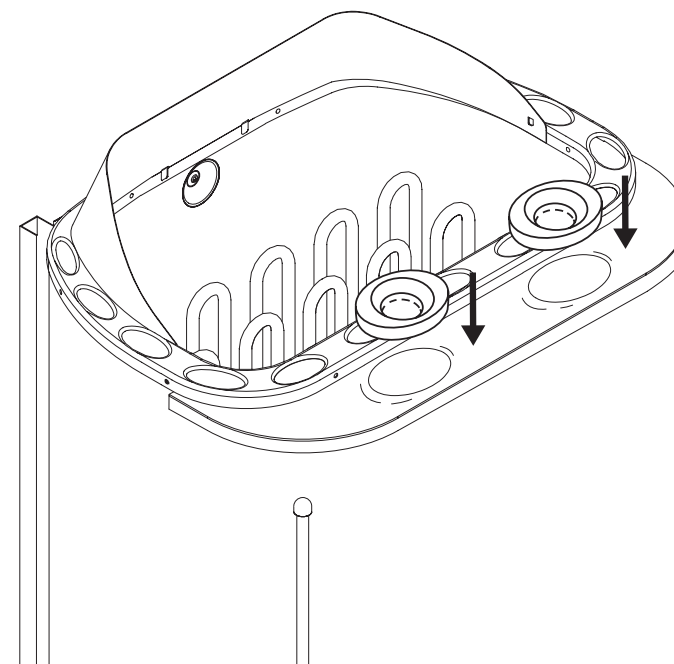

Fig. 8

8. Spare parts

1. Reflector
2. Back Frame
3. Front Frame
4. SCAC Rock Container
5. Scent Basins
6. Tank Cover
7. Wall Mounting Sheet
8. Tank
9. Heating Element
10. Middle Reflection Sheet
11. Level Indicator
12. Heating Element Holder with O-Ring
13. Temperature Limiter Switch
14. Level Indicator Hose
15. Nipple
16. Temperature Regulator
17. Ball Valve

*Refer to Fig. 9

Fig.9 Scandia combi spare parts

